

DISPLAY | Murali

DISPLAY ► MURALI

3NZ 15

CUSTOMIZATION
AVAILABLE
PERSONALIZZAZIONE
DISPONIBILE

MADE IN ITALY



30 mm

-1°C
+5°CC
ENERGY
CLASS

3 +25°C/60RH



LED

GAS
R290

DETTAGLI

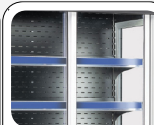
Vetro laterale
panoramicoPorte scorrevoli con
maniglia funzionaleFermaprodotti in
vetro o in plexiglassIl prodotto può
essere fornito di
ruote con frenoRipiani regolabili in
vetroAttrezzo
portabarattoli

CARATTERISTICHE GENERALI

Vetrina murale con porte scorrevoli (Larghezza: 1510mm)	•
Armadio con interno ed esterno in acciaio verniciato nero	•
Refrigerazione Ventilata	•
Schiumatura in Ciclopentano (30mm di spessore per lato - Senza CFC)	•
Sbrinamento automatico a fermata compressore	•
Controllo con display digitale	•
Luce interna LED	•
Doppio vetro anti-condensazione	•
Ripiani regolabili: 5 Pcs	•
Vetro laterale panoramico per massimizzare la vista del prodotto	•
Finiture e pannello frontale in alluminio	•
Paraurti in colore nero	•
N.4 Piedini regolabili	•
Classe energetica: C	•

SPECIFICHE TECNICHE

Capacità	912 L
Temperatura	M1 (-1°C-+5°C)
Consumo	9.7 kWh/24h
Potenza Nominale	817 W
Rumorosità	70 dB(A)
Peso Netto	268 Kg
Peso Lordo	314 Kg
Dimensioni Esterne (LxPxH mm)	1510x635x2096
Dimensioni Interne (LxPxH mm)	1446x335x1405
Dimensioni Imballo (LxPxH mm)	1620x760x2200
Quantità di carico 20'/40'/40'HQ	7/15/15

CERTIFICAZIONI

CE RoHS

INGOMBRO PRODOTTO

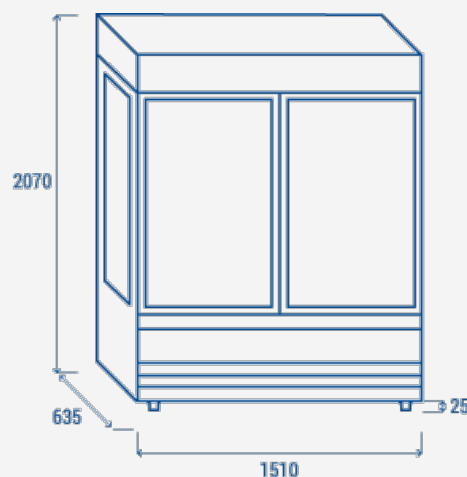
COOL HEAD EUROPE
We make the world a cooler place

www.coolheadeurope.com